

HI922 AUTOSAMPLER



INSTRUCTION MANUAL

**Dear
Customer,**

Thank you for choosing a Hanna Instruments product.

This manual has been written for the [HI922](#) Autosampler.

Please read this instruction manual carefully before using the instrument. The manual will provide you with all the necessary information on how to correctly setup the autosampler.

For more information on the autosampler's functionality see [HI932](#) Automatic Potentiometric Titrator Manual, **Chapter 12**.

If you need additional technical information, do not hesitate to e-mail us at tech@hannainst.com or view our worldwide contact list at www.hannainst.com for the nearest Hanna Instruments representative.

© 2018 Hanna Instruments

All rights are reserved. Reproduction in whole or in part is prohibited without the written consent of the copyright owner, Hanna Instruments Inc., Woonsocket, Rhode Island, 02895, USA.

1. INTRODUCTION	5
2. UNPACKING	5
3. SAFETY MEASURES	6
4. INSTALLATION	7
4.1. AUTOSAMPLER FRONT VIEW	7
4.2. AUTOSAMPLER REAR VIEW	7
4.3. AUTOSAMPLER SIDE VIEW	8
5. AUTOSAMPLER ASSEMBLY	8
5.1. BURETTE ASSEMBLY	8
5.1.1. DISASSEMBLING THE BURETTE	8
5.1.2. ASSEMBLING THE BURETTE	9
5.2. ATTACHING THE CABLE CARRIER	9
5.3. SETTING UP DISPENSER HEAD	10
5.4. CONNECTING PUMP TUBES	11
5.5. INSTALLING THE TRAY	12
5.6. ELECTRICAL CONNECTIONS	13
6. OPERATION	14
6.1. STATUS LIGHTS	14
6.2. CONTROL PANEL	14
7. MAINTENANCE	15
7.1. REPLACING PERISTALTIC PUMP TUBING	15
7.2. REMOVING A PUMP	16
7.3. ADDING A PUMP	16
7.4. UPGRADING FIRMWARE	17
8. TECHNICAL SPECIFICATION	18
9. AUTOSAMPLER COMPONENTS	19

1. INTRODUCTION

The **HI922** Autosampler is designed to automate a wide variety of potentiometric titrations in conjunction with the **HI932** Automatic Titrator. The **HI922** allows users to perform high-speed analysis while obtaining accurate results with minimal user interference.

Sequence reports and individual titration reports can be transferred to a PC via a USB interface, saved to a USB storage device or printed directly from the titrator.

A barcode reader, balance, external monitor and keyboard can be attached for added convenience.

2. UNPACKING

The autosampler and the accessories are shipped in a single box containing:

ITEM	QUANTITY
Autosampler.....	1 pc.
Control Panel.....	1 pc.
Tray Locking Screw	1 pc.
Titrant Dispensing Tube	1 pc.
Electrode Holder	1 pc.
Communication Cable	1 pc.
BNC Extension Cable	1 pc.
Temperature Sensor	1 pc.
Beaker Tray Assembly	1 pc.
Plastic Beaker	20 pcs.
Stir Bars (25 mm x 7 mm)	10 pcs.
USB Flash Drive	1 pc.
Instruction Manual.....	1 pc.
Quality Certificate	1 pc.

For a complete list of Autosampler Components with part numbers and pictures, see page 19.

If any of the items are missing or damaged, please notify your nearest Hanna Instruments Service Center.

Note: *Save all packing materials until you are sure that the instrument functions correctly. Any damaged or defective items must be returned in their original packing materials together with the supplied accessories.*

3. SAFETY MEASURES

The following safety measures must be followed:

1. Ensure that the titrator and autosampler are turned off before connecting or disconnecting pump assemblies.
2. Verify that the pumps and the attached tubing are assembled correctly.
3. Always check that the reagent and waste bottles are placed on a flat, stable surface and the titration beakers are placed in the tray.
4. Always wipe up spills and splashes immediately.
5. Avoid the following environmental working conditions:
 - Severe vibrations
 - Direct sunlight
 - Atmospheric relative humidity above 95% non-condensing
 - Environment temperatures below 10°C and above 40°C
 - Explosion hazards
6. Have the autosampler serviced by qualified service personnel only.
7. Keep hands and objects clear of moving parts during operation.

In an emergency situation, the autosampler can be stopped immediately by pressing either of the illuminated emergency stop buttons located at the top corners of the autosampler tower.

This action will immediately deactivate motors and pumps.

To reset the emergency stop, press and hold both emergency buttons for five seconds until the status lights turn from red to yellow to green.

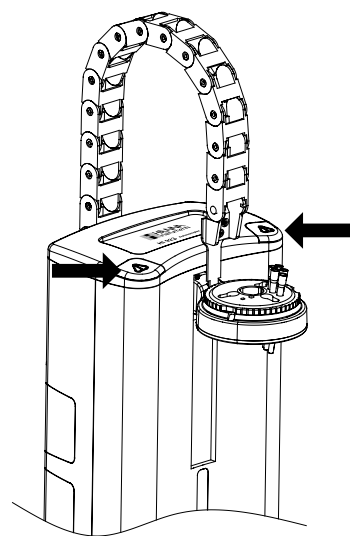

4. INSTALLATION

4.1 AUTOSAMPLER FRONT VIEW

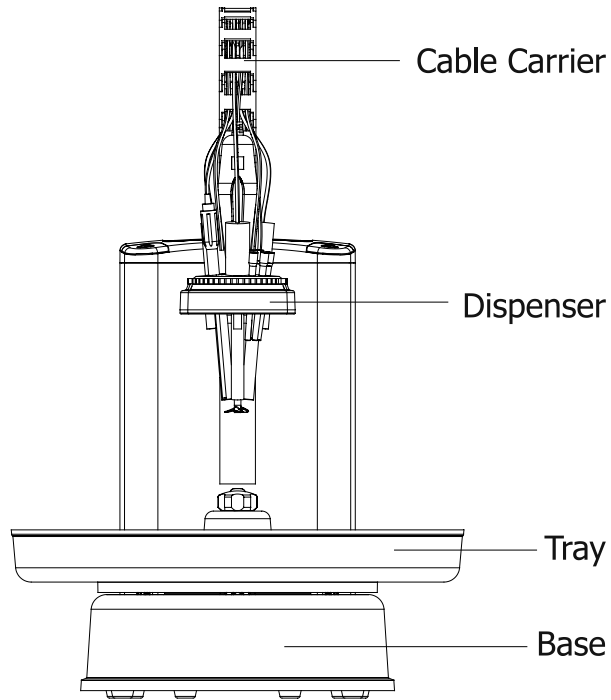

4.2 AUTOSAMPLER REAR VIEW

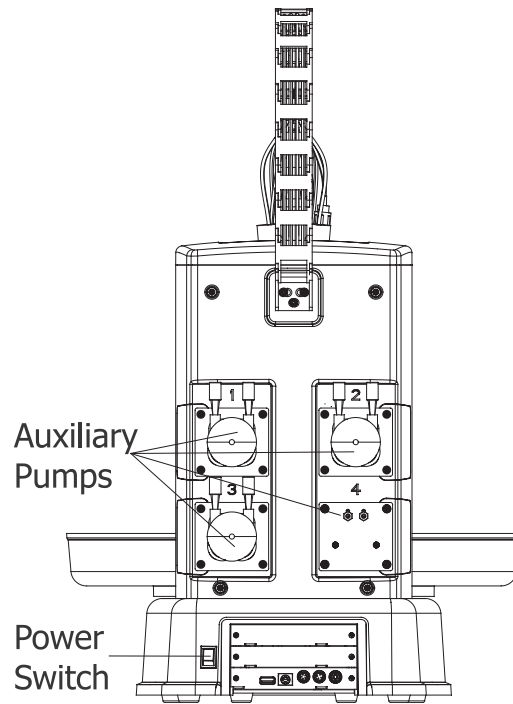

4.3. AUTOSAMPLER SIDE VIEW

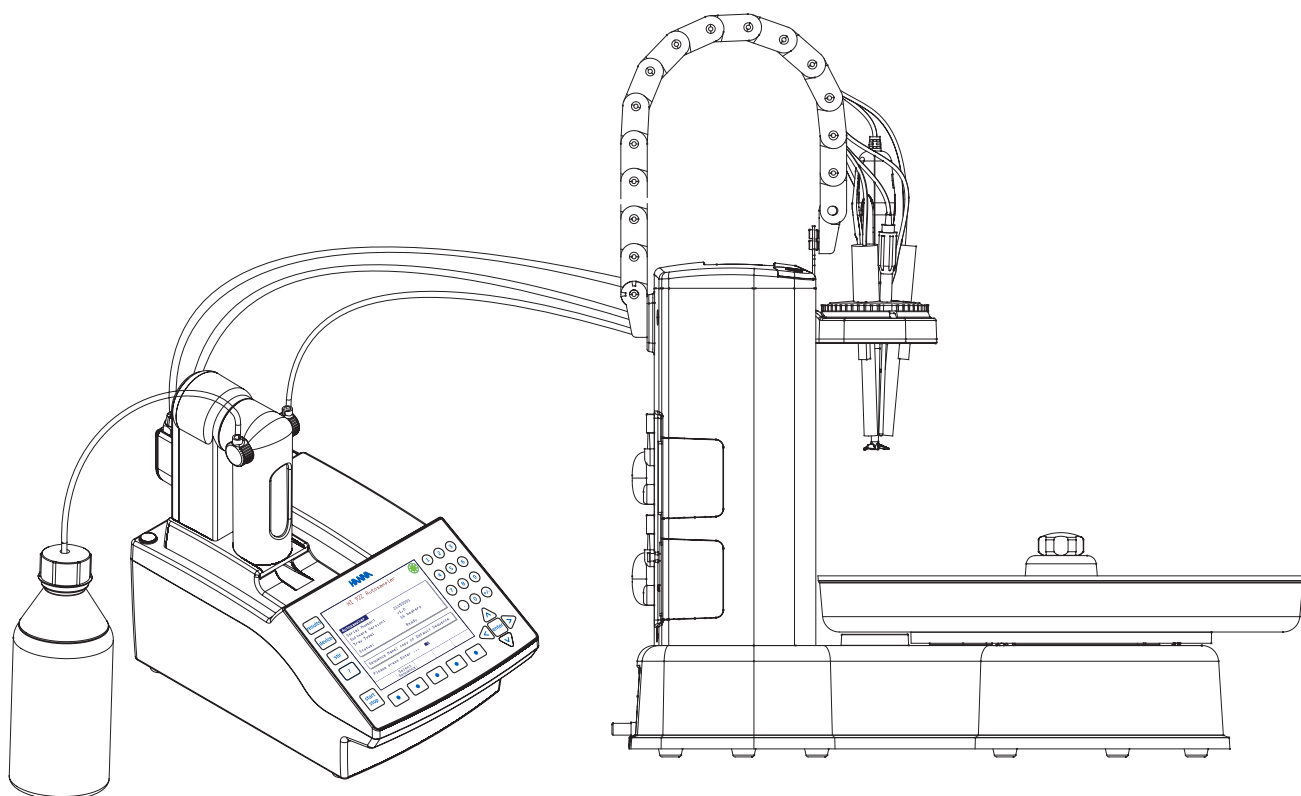

5. AUTOSAMPLER ASSEMBLY

5.1. BURETTE ASSEMBLY

5.1.1. DISASSEMBLING THE BURETTE

The aspiration and the dispensing tubes have fittings and tube protectors. The aspiration tube is mounted on the left side and the dispensing tube is mounted on the right side of the burette.

To remove the dispensing tube follow these steps:

- Remove the blue tube protector (A) by sliding it off the clear titrant tubing.
- Remove the tube lock (B) from the burette holder.
- Turn the fitting (C) counterclockwise to remove it from the burette holder.
- Slide the clear titrant tubing through the fitting.

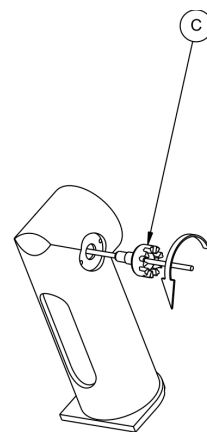
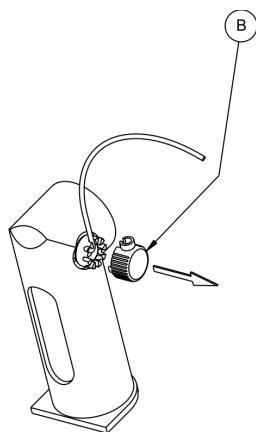
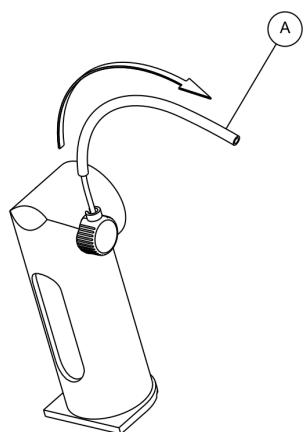

5.1.2. ASSEMBLING THE BURETTE

To attach the dispensing tube, follow these steps:

- Insert the flat-shaped end of the titrant tubing into the valve outlet (A) and screw the fitting clockwise to tighten. The highest of the 9 cuts should be vertical in the final position.
- Straighten out tube up into the vertical position to enter the highest cut of the fitting (C).
- Attach the tube lock fitting (D).
- Attach the blue tube protector (E) by sliding it over the clear titrant tubing, the protector will be positioned in the tube lock fitting

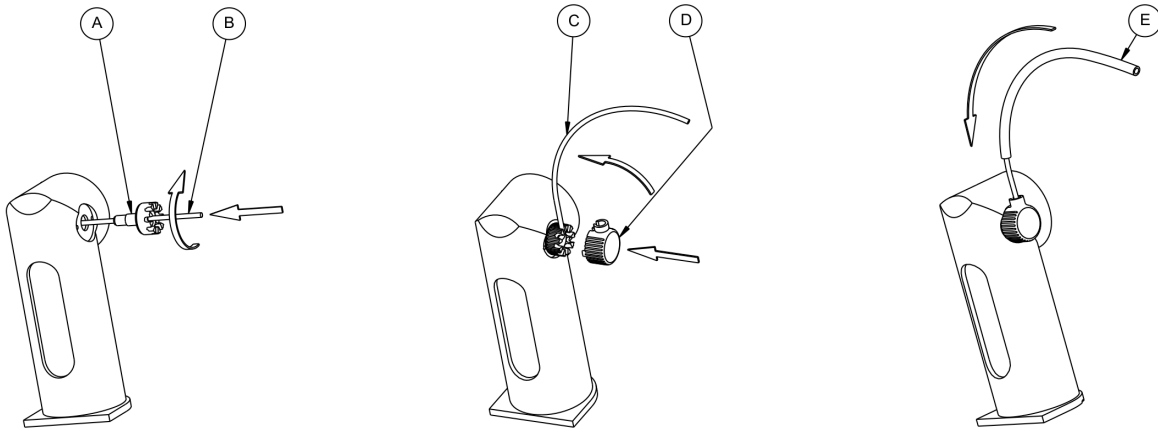

5.2. ATTACHING THE CABLE CARRIER

To attach the cable carrier remove the three (3) screws from the top rear panel (A). Align the screw holes on the cable carrier (B) to the rear panel and tighten the screws.

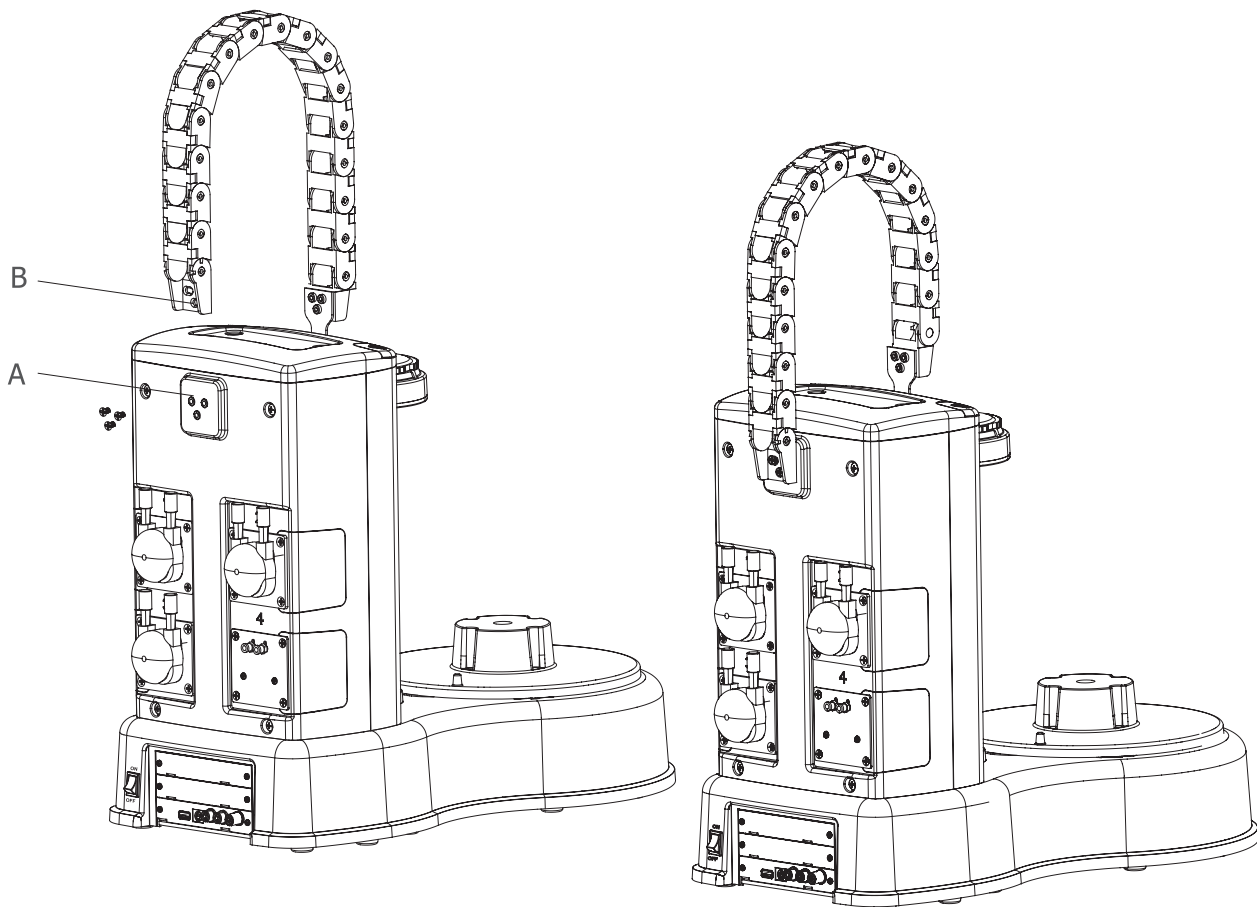

5.3. SETTING UP THE DISPENSER HEAD

To set up the dispenser head follow these steps:

- Release the clips from the cable carrier by using a flat head screwdriver.
- Insert electrode, temperature sensor, stirrer, and aspiration tube (optional) into the dedicated holes in the electrode holder. Push them down until they are in a stable position.
- Insert burette and auxiliary tubing into the appropriate holders.
- Close clips on cable carrier once all cables and tubing are positioned.

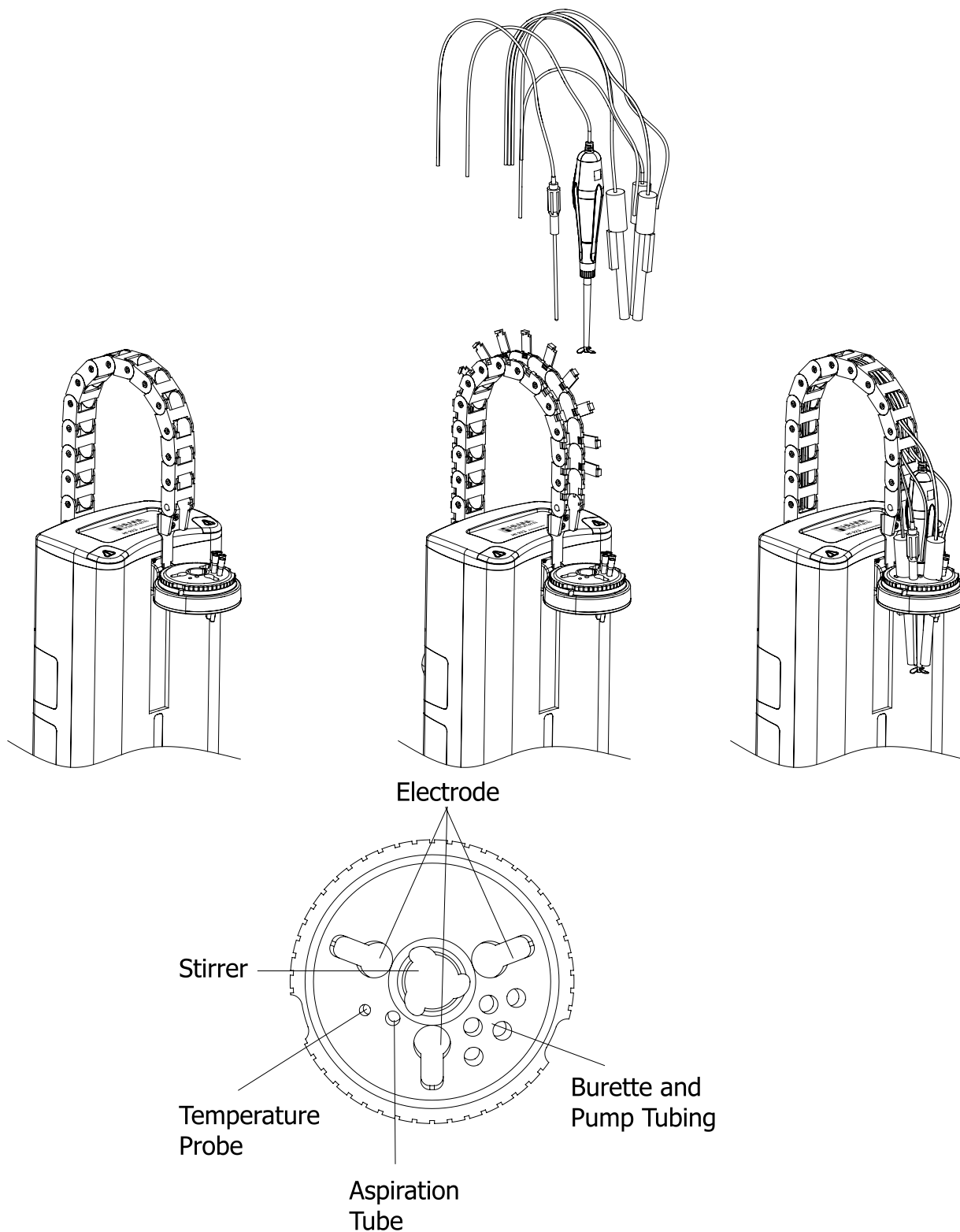

5.4. CONNECTING PUMP TUBES

PERISTALTIC PUMPS

Addition Operation:

To dispenser head To reagent container

Aspiration Operation:

To waste container To dispenser head

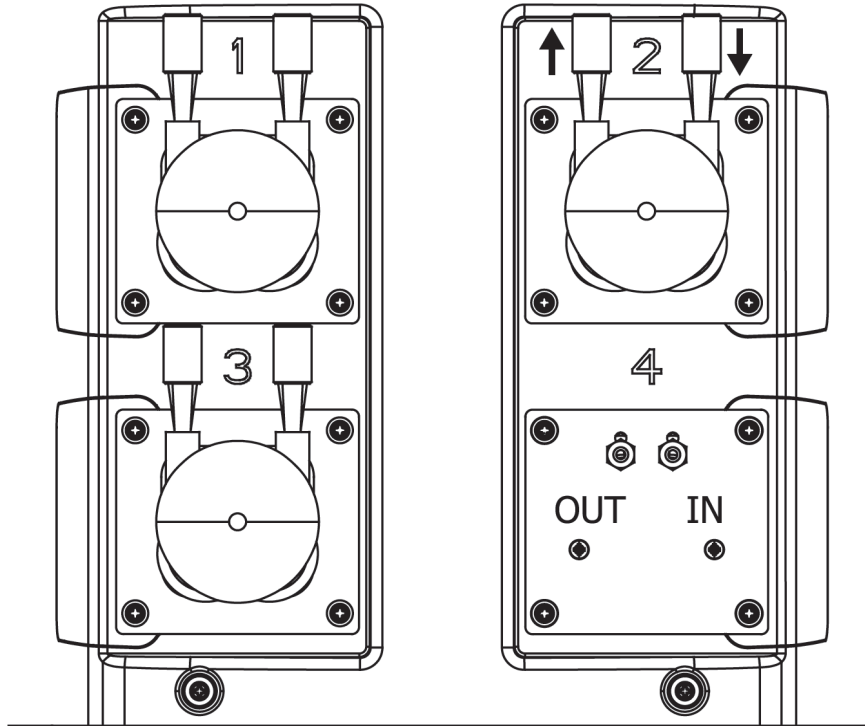

For Reagent Addition Operation:

- Connect the dispensing tubing to the left side of the peristaltic pump.
- Connect the reagent container tubing to the right side of the peristaltic pump.

For Waste Aspiration Operation:

- Connect the waste container tubing to the left side of the peristaltic pump.
- Connect the aspiration tubing to the right side of the peristaltic pump.

5.5. INSTALLING THE TRAY

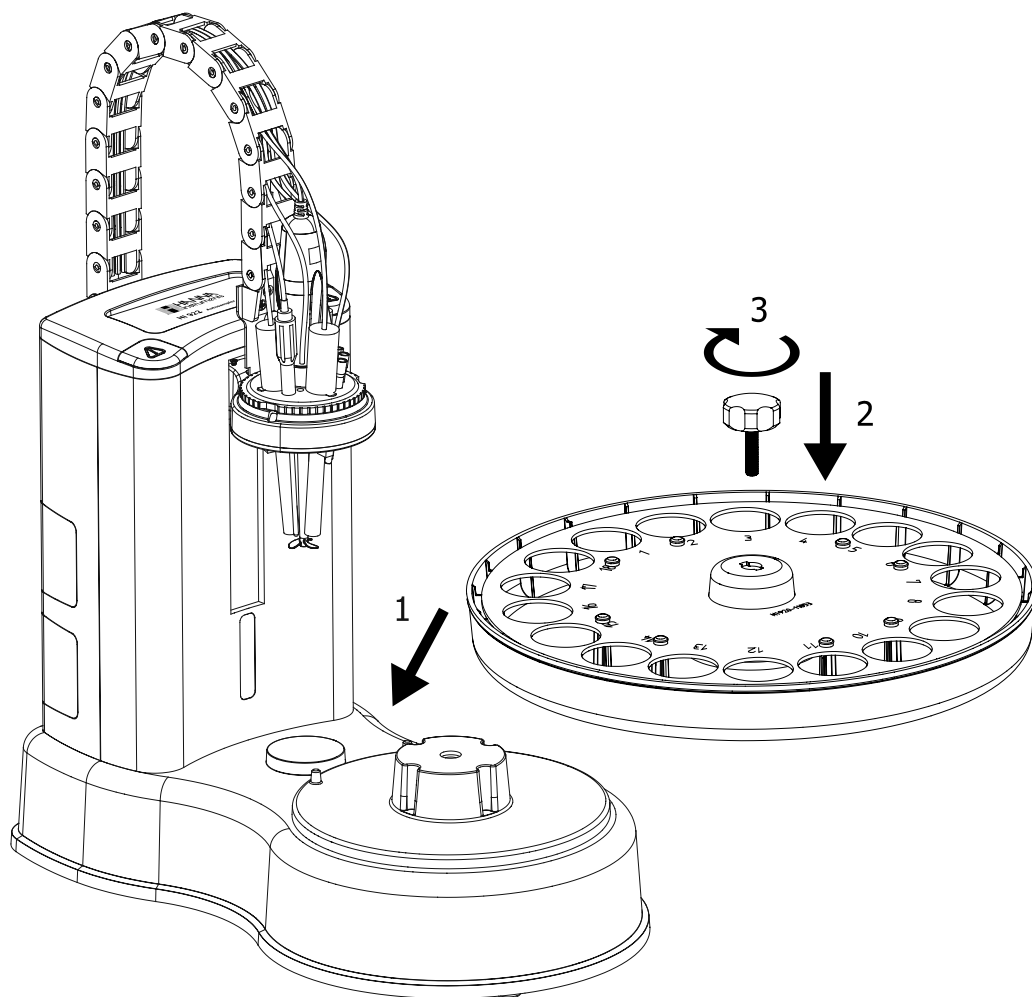

- Place the tray on the turntable with Beaker 1 under the dispenser. Make sure the turntable mounting pins are aligned with the tray.
- Lock the tray in place with the locking screw. Do not overtighten the locking screw!

5.6. ELECTRICAL CONNECTIONS

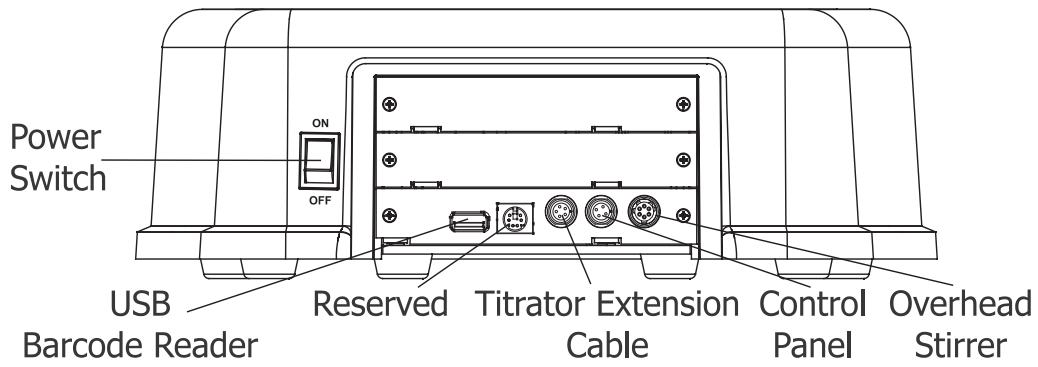

- Connect the titrator to *Titration* connector;
- Connect the control panel to *Control Panel* connector;
- Connect the overhead stirrer (optional) to *Stirrer* connector;
- Connect a USB barcode reader (optional) to the *USB* port.

6. OPERATION

6.1. STATUS LIGHTS

The status lights serve as a visual indication of the autosampler's current status:

- Green (steady):** Idle, ready for commands
- Green (flashing):** Running
- Yellow (steady):** Firmware is updating
- Yellow (flashing):** Paused, waiting for user action
- Red (flashing):** Error
- Red (steady):** Firmware corrupted. Autosampler initializing (first 3 seconds after power on)

6.2. CONTROL PANEL

The control panel displays the current status of the autosampler and can be used to manually control the autosampler while it is idle (green steady status lights).

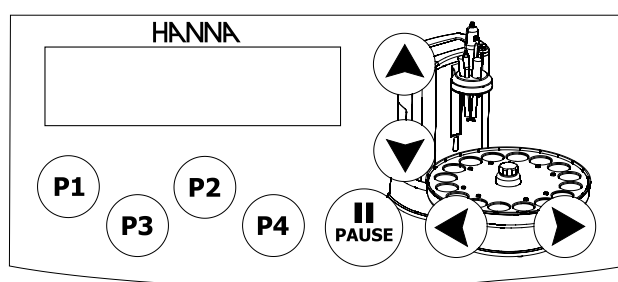

 /  : Move the dispenser head up/down

 /  : Rotate the turnable clockwise/counterclockwise

 -  : Power the auxiliary pumps

 : Suspends/resumes automatic mode

7. MAINTENANCE

7.1. REPLACING PERISTALTIC PUMP TUBING

Peristaltic pump tubing wears over time and will occasionally require replacement. To replace tubing:

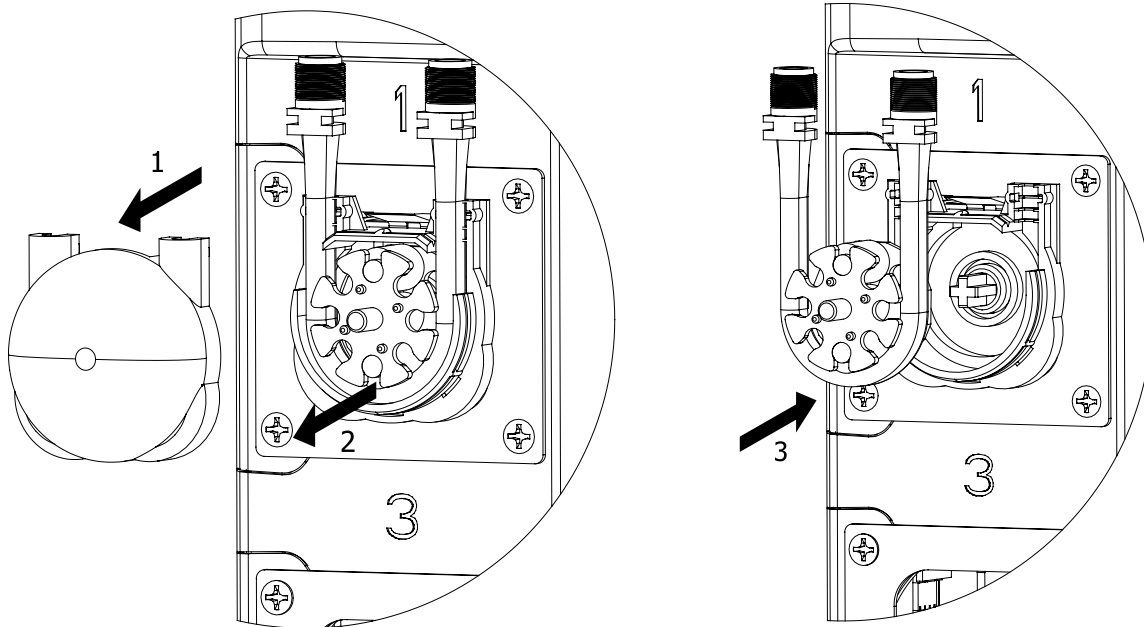

- Pull the clear plastic cover off of the pump (1)
- Remove the plastic rotor and tubing (2)
- Thoroughly grease the outside of the replacement tube and the rotor's rollers
- Wrap the replacement tubing around the rotor and press into the pump housing (3). The tubing in contact with the rollers will need to be compressed with a finger in order to fit in the housing
- Replace the clear plastic cover

WARNING! Turn off the autosampler and disconnect from the titrator before adding or removing pumps! Failure to do so could cause damage to the pump and/or autosampler.

7.2. REMOVING A PUMP

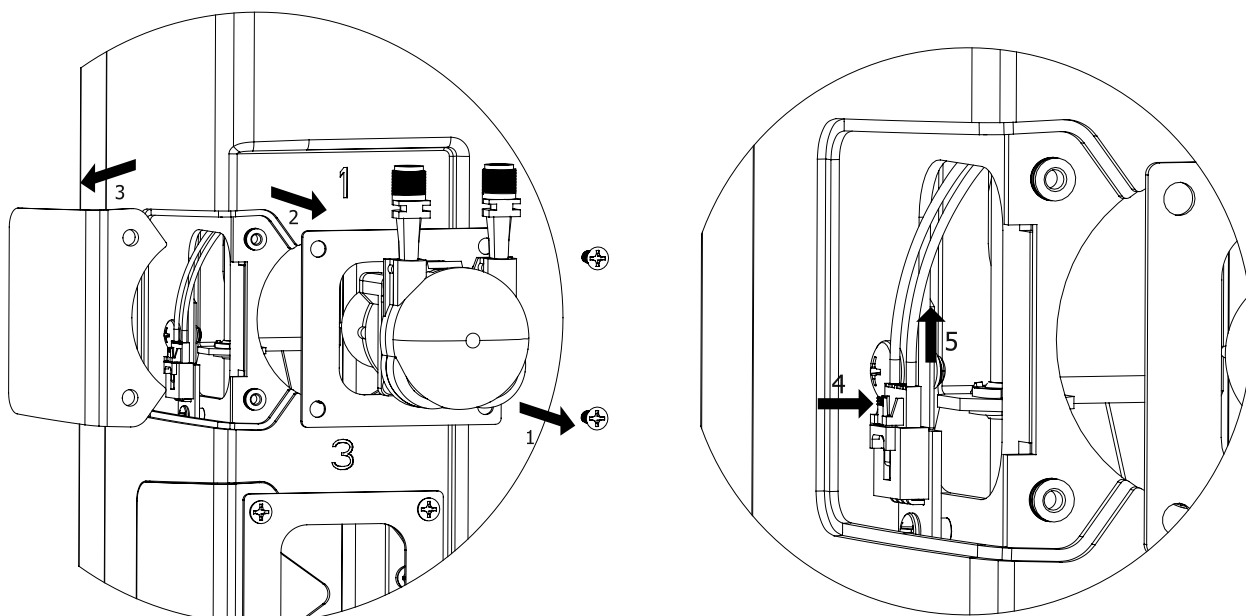

- Remove the 4 screws holding the pump in the autosampler tower (1).
- Pull the pump out (2) of the tower slightly so that the pump's side cover can be removed (3).
- Disconnect the pump's electrical connection by holding down the connector release tab (4) while pulling the connector away from the circuit board (5).
- Pull the pump out of the autosampler tower.
- If the pump's bay is no longer being used, replace the side and back covers and fasten with the 4 screws.

7.3. ADDING A PUMP

Peristaltic pumps can only be connected to bay #1, #2, and #3. Membrane pump can only be connected to bay #4.

- Remove the 4 screws holding side and rear covers of the pump bay.
- Insert the pump into the rear of the autosampler tower.
- Once inside the tower, pull the pump's electrical connector out of the side of the tower. Push the connector into the circuit board with the push-tab facing the outside of the tower.
- Replace the side cover. You will need to pull the pump out of the tower slightly.
- Fasten the pump in place with 4 screws.

7.4. UPGRADING FIRMWARE

The **HI922** firmware can be upgraded via the USB connector. The current firmware version is displayed on the control panel during boot-up and on the Autosampler Information screen. To upgrade the firmware:

1. Load the upgrade file into the root directory of a flash drive. Firmware files are named following “922v# # # # .hex” format.
2. Power off the **HI922** Autosampler using the power switch, but leave the cable connected to the **HI932** Titrator.
3. Insert the USB flash drive with upgrade file in the **HI922** USB port.
4. While holding down both emergency stop buttons, turn on the **HI922** Autosampler. Keep the buttons pressed until the status lights turn yellow. The control panel should display the message “Upgrading FW, please wait. . .”. After this message appears, release the buttons and wait for the upgrading operation to be completed.
5. After the upgrade has been completed, the status lights will turn green and the control panel will display “Upgrade Complete”. Remove the USB flash drive.

8. TECHNICAL SPECIFICATIONS

	5 x multi-purpose slots (titrant/reagent tubes) 3 x 12-mm electrodes slots
Electrode Holder	1 x overhead stirrer slot 1 x temperature sensor slot 1 x aspiration tube slot
Stirrer	magnetic stirrer (built-in) overhead stirrer (optional)
Temperature Sensor	HI7662-AW (included)
Peristaltic Pumps	Up to three (Slots 1, 2 & 3)
Diaphragm Pumps	One (Slot 4)
Peripheral Units	USB Barcode Reader
Trays	16 beakers x 150 mL with Built-in RFID 18 beakers x 100 mL with Built-in RFID
Beakers	ASTM short-form glass beakers, 100 & 150 mL HI920-060 (150 mL), Plastic beakers HI920-053 (100 mL), Plastic beakers
Control Panel	Buttons for manual operation of tray Manual operation of peristaltic or diaphragm pumps 2-line backlight display with status information
Enclosure Material	ABS plastic and steel
Electrode Holder Material	ABS plastic
Tray Material	ABS plastic and acrylic
Keypad Material	ABS plastic and polycarbonate
Weight	approx. 13 kg (29 lbs)
Operating Environment	10 to 40°C, up to 95% relative humidity (non-condensing)
Storage Environment	-20 to 70°C, up to 95% relative humidity (non-condensing)

9. AUTOSAMPLER COMPONENTS

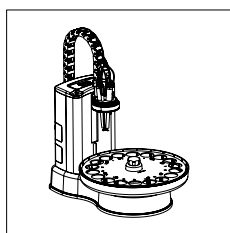

Autosampler
HI922 - XYZ

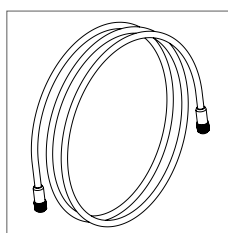

Communication Cable
HI920-933
(HI932 to HI921/HI922)

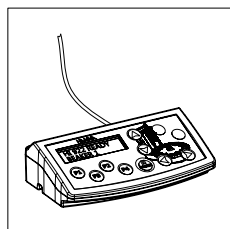

Control Panel
HI920-922

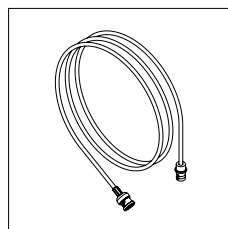

BNC Extension Cable (1 m)
HI920-931

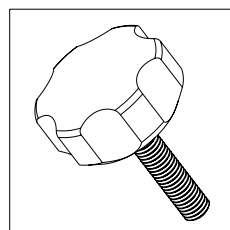

Tray Locking Screw
HI920-960

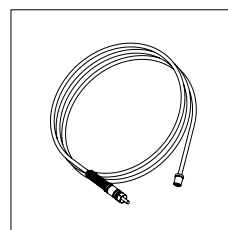

Reference Extension Cable (1 m)
HI920-932

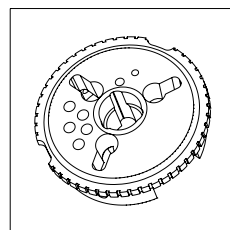

Electrode Holder
HI920-310

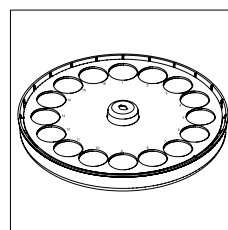

16 Beaker Tray, 60 mm dia.
Single Row with RFID
HI920-11660W

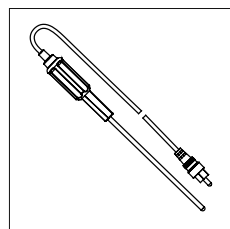

Temperature Sensor
HI7662-AW

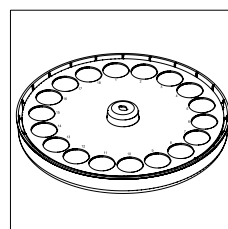

18 Beaker Tray, 53 mm dia.
Single Row with RFID
HI920-11853W

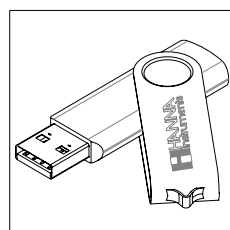

USB Flash Drive
HI920-901

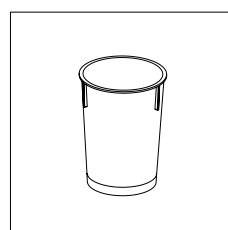

Plastic Beaker for
HI920-11660 (20 pcs.)
HI920-060

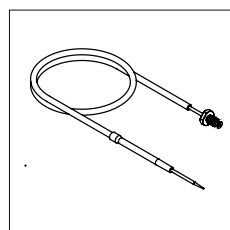

Titrant Dispensing Tube (1.5 m)
HI920-281

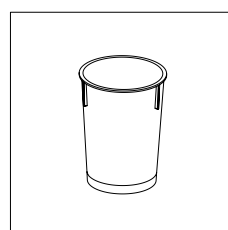

Plastic Beaker for
HI920-11853 (20 pcs.)
HI920-053

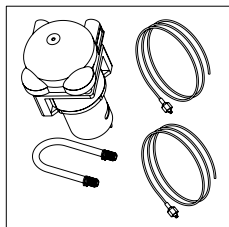

Peristaltic Pump with dispensing tubing
HI920-103

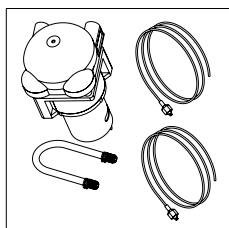

Peristaltic pump with aspiration tubing
HI920-104

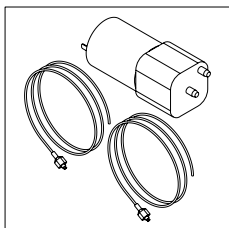

Membrane Pump with tubing
HI920-113

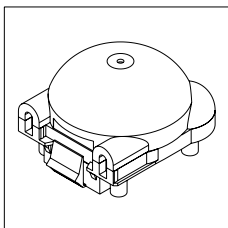

Replacement Cap and Rotor for
Peristaltic Pump
HI920-201

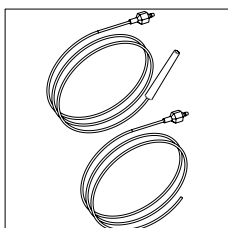

Tubing Set with plastic dispensing
tube for peristaltic pump
HI920-208

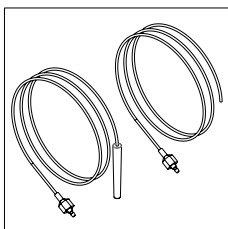

Tubing Set with stainless steel
aspiration tube for peristaltic pump
HI920-203

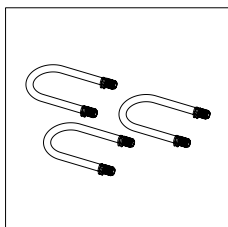

Roller Tube for Autosampler peristaltic
pump (3 pcs.)
HI920-204

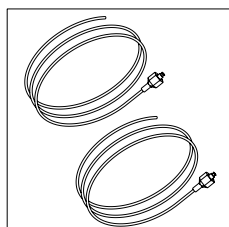

Membrane Pump Complete Tubing Set
HI920-212

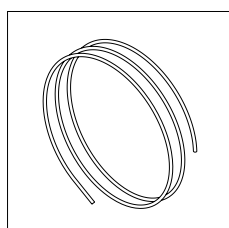

TYGON Tube (5 m)
HI920-290

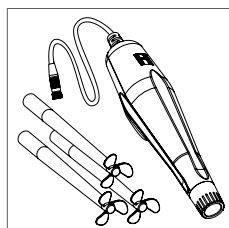

Overhead Stirrer +
3 propellers
HI930301

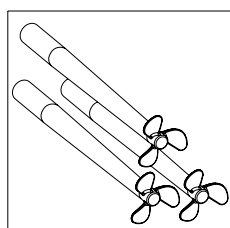

Replacement Propellers
(3 pcs.)
HI930302

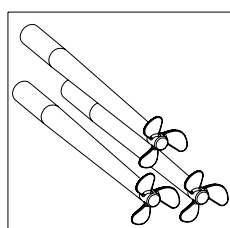

High Chemical Resistance Propellers
(3 pcs.)
HI930303

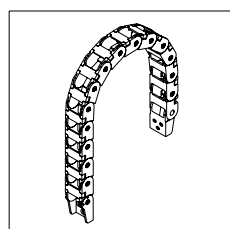

Cable Chain
HI920-320

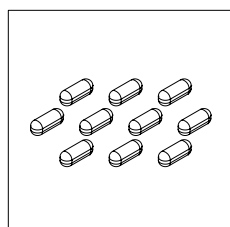

25 mm x 7 mm Stir Bars (10 pcs.)
HI731319

Certification

All Hanna Instruments conform to the **CE European Directives**.



RoHS
compliant

Disposal of Electrical & Electronic Equipment. The product should not be treated as household waste. Instead hand it over to the appropriate collection point for the recycling of electrical and electronic equipment which will conserve natural resources.

Ensuring proper product and battery disposal prevents potential negative consequences for the environment and human health. For more information, contact your city, your local household waste disposal service, the place of purchase or go to www.hannainst.com.



Recommendations for Users

Before using this product, make sure it is entirely suitable for your specific application and for the environment in which it is used. Any variation introduced by the user to the supplied equipment may degrade the meter's performance. For yours and the meter's safety do not use or store the meter in hazardous environments.

Warranty

The HI922 is warranted for two years against defects in workmanship and materials when used for its intended purpose and maintained according to instructions. Damage due to accidents, misuse, tampering or lack of prescribed maintenance is not covered.

If service is required, contact your local Hanna Instruments Office. If under warranty, report the model number, date of purchase, serial number and the nature of the problem. If the repair is not covered by the warranty, you will be notified of the charges incurred. If the instrument is to be returned to Hanna Instruments, first obtain a Returned Goods Authorization (RGA) number from the Technical Service department and then send it with shipping costs prepaid. When shipping any instrument, make sure it is properly packed for complete protection.

World Headquarters

Hanna Instruments Inc.
Highland Industrial Park
584 Park East Drive
Woonsocket, RI 02895 USA
www.hannainst.com

Local Office

Hanna Instruments Inc.
Highland Industrial Park
584 Park East Drive
Woonsocket, RI 02895 USA
Phone: 800.426.6287
Fax: 401.765.7575
e-mail: tech@hannainst.com